



Transducer Instruction Manual

Range: Classic

Type: FLCM – 1T

Revision: V1.0

Contents

Contents	1
1. Principle of Transducer Operation	2
2. Installation	2
2.1 Selection of Transducer Mounting Location	2
2.2 Installation Precautions	3
2.3 Mounting Surface Preparation	3
2.4 Sensing Roller Balance	3
2.5 Transducer Installation	3
2.6 Sensing Roller Installation	4
2.7 Temperature Compensation and Shaft Expansion	5
2.8 Hazardous Area Installation - Intrinsic Safety	5
2.9 Single Transducer Operation	5
3. Transducer Force (MWF) Calculation	5
4. Troubleshooting	6
4.1 High Output Signal With No Tension	6
4.2 Low Output Signal With Maximum Tension	6
4.3 Wrong Polarity of Output Signal	6
4.4 Output Signal Not Linear, Zero Shifts During Operation	7
4.5 Transducer Strain Gauge Resistance	7

1. Principle of Transducer Operation

Cleveland Kidder web tension transducers utilise a sensing beam to which semi-conductor strain gauges are bonded and are used for non-rotating shaft applications. Normally a pair of transducers would be used, supporting the ends of the sensing roller shaft. The tension force applied to the sensing roller must pass freely through to the transducers, which convert this force into an electrical signal.

This signal is a combination of tension force and sensing roller dead weight. The dead weight of the roller is zeroed out electrically in the indicator or controller leaving the tension force signal only to be amplified to give a true display of measured tension.

2. Installation

2.1 Selection of Transducer Mounting Location

The transducer must be mounted in a clean, dry location, see below for hazardous area installation. When selecting a transducer mounting location, please remember that the tension sensing roller must **NOT** be mounted where the web wrap angle can vary. Any change in the wrap angle will be sensed by the transducer as a change in tension, and indicated as such on the tension meter or display.

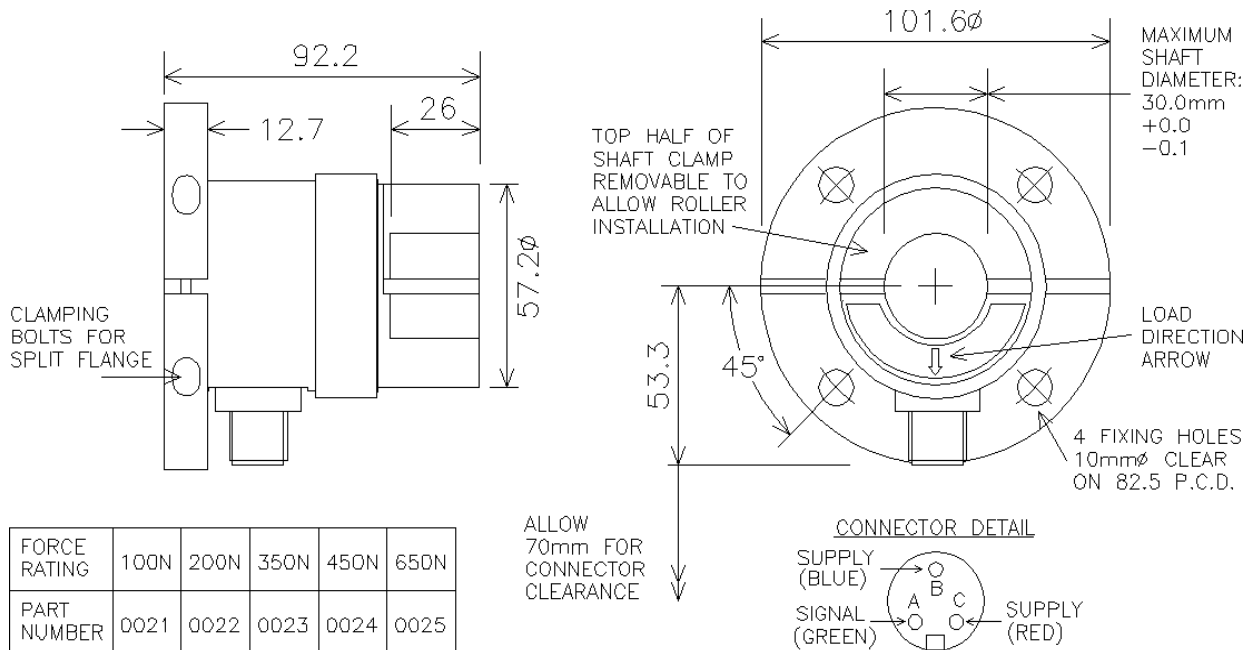

2.2 Installation Precautions

To ensure proper installation and operation of the tension system, the following steps should be performed in sequence - always install, orientate and firmly bolt down the transducer **BEFORE** installing the tension sensing roller.

Welding. Unplug the cable connector from the transducer before any electric welding is undertaken on the machine.

Transport. It is recommended that the tension sensing roller is removed from the transducer before the machine is transported to prevent excessive shock being transmitted through to the transducer.

Failure to carry out these precautions could seriously damage the transducer and invalidate the warranty.

2.3 Mounting Surface Preparation

The mounting surface for the transducer should be rigid, flat and clean. Prepare the machine frame or mounting surface by removing any loose paint, rust, scale, burrs etc.

2.4 Sensing Roller Balance

The tension sensing roller should be dynamically balanced when the roller speed exceeds 300 RPM as excessive vibration can damage the transducer. Any out of balance force should not exceed 10% of the maximum working force (**MWF**) of the transducer. The sensing roller must not be driven or have any force applied to it except by the web. Even with a balanced roller, a vibration can be set up at the critical roller speed. To ensure that this problem is avoided, the critical roller speed should be at least 20% above that attained at maximum web speed. Consult the roller manufacturer for advice.

2.5 Transducer Installation

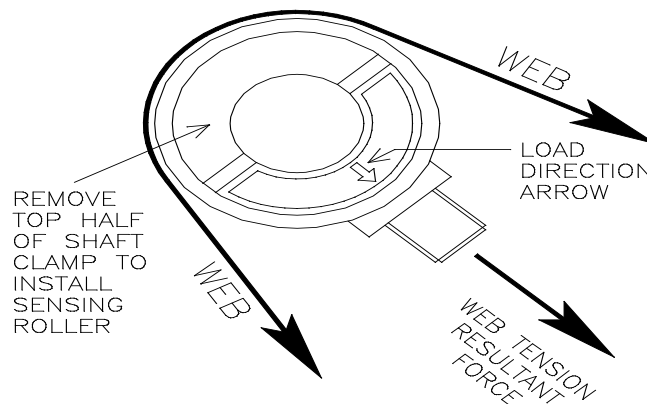

Four M10 mounting holes should be drilled in the machine frame to accept the split flange. Loosen, but do not remove the two clamping bolts for the split flange. Rotate the transducer in the split flange until the "LOAD IN THIS DIRECTION" arrow is pointing in the direction of the web tension resultant force.

The cable connector should bisect the web wrap angle.

Tighten the two clamping bolts for the split flange.

Secure the transducer firmly to the machine frame with four M10 mounting bolts.

When two transducers are fitted, check that the transducers are parallel and in line. The transducers are designed to accommodate some frame to frame misalignment. Misalignments should be less than 1 degree to prevent web tracking problems.

2.6 Sensing Roller Installation

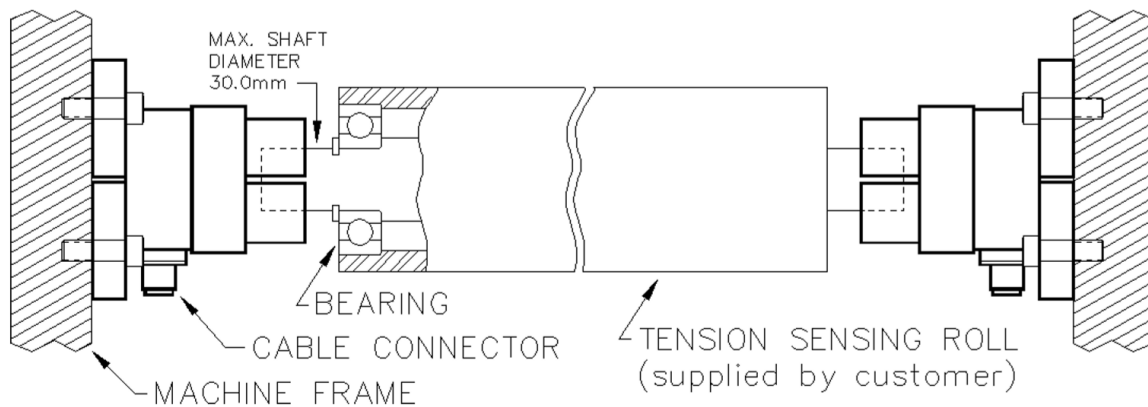

Remove the top half of the transducer shaft clamp by removing the 4 shaft clamp screws.

Mount the tension sensing roller in the transducer. Clearance between the end of the shaft and the transducer shaft clamp should be from 0.5mm to 1mm. Do **NOT** rotate the transducer for orientation with the tension sensing roller installed. This may cause damage to the transducer.

Fasten the transducer shaft clamp securely.

If shaft diameter reducing bushings are required, use split bushings of the correct length obtainable from CMC Controls. Do **NOT** overhang the transducer I.D. and shaft O.D. Do **NOT** use solid bushings. The lengthwise split in the bushing should be directly in line with the gap between the transducer shaft clamp and the transducer head. Fasten the transducer shaft clamp securely.

When dismantling an installation, do **NOT** remove the transducers and the tension sensing roller as an assembly. Remove the sensing roller first by removing the shaft clamps, before loosening the transducer mounting bolts.

2.7 Temperature Compensation and Shaft Expansion

The transducer is supplied with a temperature compensation network which is in series with Pin A, the output signal lead. The compensation circuit will operate correctly only when used with a tension indicator or controller supplied by CMC Controls. The transducer can accommodate sensing roller shaft expansion due to normal temperature changes. The transducer, sensing roller and machine structure should all therefore be at normal room temperature during installation.

2.8 Hazardous Area Installation - Intrinsic Safety

CMC Controls tension transducers can be located in a hazardous area to provide an Intrinsically Safe installation to EN 50039 when a proprietary Zener Barrier module, Part Number 4503, is used. Tension transducers are passive components and are classified as simple apparatus by EN 50014. Strain gauge transducers (load cells) will be damaged if subjected to the 500 volt insulation test required by EN 50020. To comply with Intrinsic Safety regulations the body of the transducer must be bonded to the IS earth using 4 square millimetre green/yellow insulated cable. Consult CMC Controls for more information.

NOTE It is the responsibility of the user to ensure that all relevant safety regulations are complied with. The integrity of all connections particularly the earth should form part of any maintenance procedure.

2.9 Single Transducer Operation

Most web tension installations require two transducers, each supporting one end of the sensing roller shaft and the transducer output signals are summed to give a measurement of Total tension. For those installations where only one transducer is required a Dummy Transducer, Part Number 4431, may be needed to complete the full Wheatstone bridge. For single transducer installations the MWF calculation, see below, should be derated by a factor of 1.5, consult CMC Controls for more information.

3. Transducer Force (MWF) Calculation

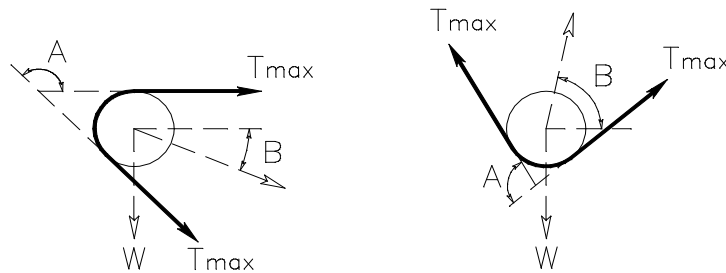

The formula for calculation of the transducer maximum working force (**MWF**) or force rating allows a 100% overload for tension transients or a tight edge to the web.

Remember to use the correct units.

To convert W in Kg to Newtons - N multiply by 10, the exact factor is 9.81

$$MWF = 2 T_{max} \sin(A/2) + (W/2) \sin(B) \quad MWF = 2 T_{max} \sin(A/2) - (W/2) \sin(B)$$

MWF MUST BE GREATER THAN SENSING ROLLER WEIGHT W
 ANGLE 'A' IS 30 DEGREES MINIMUM

4. Troubleshooting

There are no user replaceable or serviceable parts in the transducer. Tampering or damage caused during installation will invalidate the warranty.

The signal output from the transducer with the recommended 5.6V DC excitation is 250mV (nominal) when the transducer is loaded to its maximum working force - MWF.

The transducer has built in mechanical overload stops which operate at approximately 125% of the MWF. Forces above 150% of MWF particularly transients or tension snatches may cause permanent damage. The ultimate overload capability before breakage is 300%, bearing damage may occur before this.

4.1 High Output Signal With No Tension

- [1] Check for correct wiring to the transducer.
- [2] Check cables and connectors for good continuity with an ohm meter, do **NOT** use a 'megger'.
- [3] The transducer may have too low a MWF, replace with a higher MWF transducer or reduce the web wrap angle.
- [4] The transducer excitation voltage may be too high - this will cause permanent damage and may invalidate the warranty.
- [5] There may be a high degree of misalignment of the transducers causing a severe pre-load.
- [6] The sensing roller weight may be too heavy, this should not exceed the MWF of the transducer.

4.2 Low Output Signal With Maximum Tension

- [1] Check for correct wiring to the transducer.
- [2] Check cables and connectors for good continuity with an ohm meter, do **NOT** use a 'megger'.
- [3] The transducer may have too high a MWF, replace with a lower MWF transducer or increase the web wrap angle.
- [4] The transducer excitation voltage may be too low.

4.3 Wrong Polarity of Output Signal

- [1] Check that the web path is correct.
- [2] The transducer may be incorrectly orientated, rotate 180° to correct this. If rotation is not possible, interchange the transducer excitation supply or output signal leads at the indicator or controller terminals.

4.4 Output Signal Not Linear, Zero Shifts During Operation

- [1] Check that there is no dirt or foreign matter interfering with the transducer mounting.
- [2] Check that the shaft clamp and transducer mounting bolts are secure.

4.5 Transducer Strain Gauge Resistance

The transducer has two semiconductor strain gauges in a half bridge configuration. The temperature compensation network is in series with the output signal lead Pin A. The gauge resistances, measured at room temperature with no load, are shown in the table below.

Measurement	Resistance – Ohms Ω
Pin B to Pin C	240 +/- 35 Ω
Pin A to Pin B	700 to 1100 Ω
Pin A to Pin C	Pin A to Pin B +/- 5 Ω
Pins A, B or C to body	> 20 M Ω