



Amplifier Instruction Manual

Range: LETIX
Type: L-ANV-0-0-R-AC
Supply: 110-240V AC
Output: 0-10V
Revision: V1.0

Contents

Contents.....	1
1. General Description	2
2. Installation	3
2.1 Mechanical.....	3
2.2 Unit Electrical Connection Diagram	3
2.3 Transducer Electrical Connection Diagrams	4
2.4 Supply Connection Diagram.....	6
3. Supply Voltage	7
4. Calibration.....	7
4.1 Indicator.....	7
4.2 Direct Calibration – Full Scale Setting	8
4.3 Decimal Point	8
4.4 Display value	8
4.5 Direct Calibration – Zero Scale Setting	8
4.6 Output Signal Calibration.....	8
5. Troubleshooting.....	9
5.1 Digital Display Not Illuminated When Indicator Is Switched On.....	9
5.2 Verify The Transducer Connections.....	9
5.3 Check The Display Is Reading Correctly When The Transducers Are Loaded.....	9

1. General Description



The LETIX Digital Web Tension Indicator continuously displays the true web tension either as a percentage of total tension or in real engineering units.

The measurement of actual web tension is made by sensing, with strain gauge transducers (sometimes referred to as 'load cells'), the force on a sensing roller caused by the tension in the web. The electrical signal from the transducers is a combination of tension force and sensing roller deadweight.

The effect of the weight of the sensing roller is removed electrically, leaving the tension force signal only to be displayed on the meter.

The LETIX indicator uses high specification A/D and D/A converters, power supply, and a bright LED digital display, all housed in a standard DIN size case. The LETIX features as standard a transducer bridge supply excitation of 5v (or 10v) DC, an independently scalable digital display and an isolated analogue output (0 to +10V at 2mA maximum). It can be used as a remote display and/or as the input to a control system.

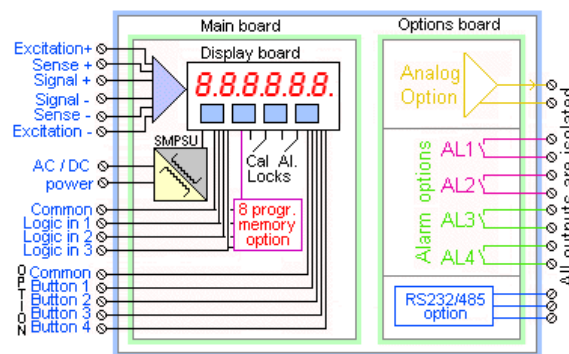

The Indicator can accept full scale input voltages of either up to +/- 40 mV (foil strain gauges) or up to +/- 400 mV (semi-conductor strain gauges) for full display with selectable decimal point position and scaling, and a zero offset for both positive and negative sensing.

2. Installation

2.1 Mechanical

The installation of this unit **MUST** be carried out by a competent person who has the relevant knowledge and ability to install the unit in a safe manner, The installation is not the responsibility of CMC Controls or Absolute Measurement Ltd.

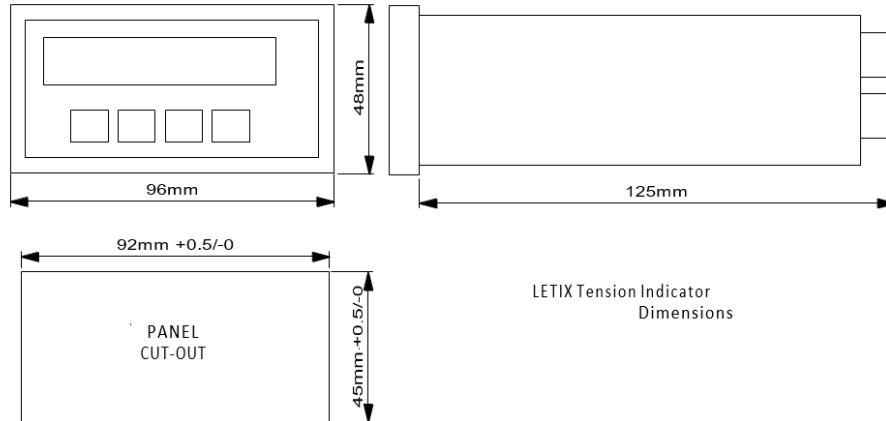

The Indicator must be installed in a dry, non-hazardous location. A panel cut out of 92 mm (+1.0/0.0 mm) x 45 mm (+1.0/0.0 mm) is required. The depth of the Indicator is 125 mm but extra provision must be allowed for cable connections. A single fixing clip, behind the unit, retains the Indicator. To install, simply insert the Indicator into the cut out and fit the clip to hold the Indicator in place.

The tension transducers must be installed in accordance with the installation procedure from the transducer handbook. See the transducer part of the handbook or a specific drawing for the connection details and wire colours.

2.2 Unit Electrical Connection Diagram

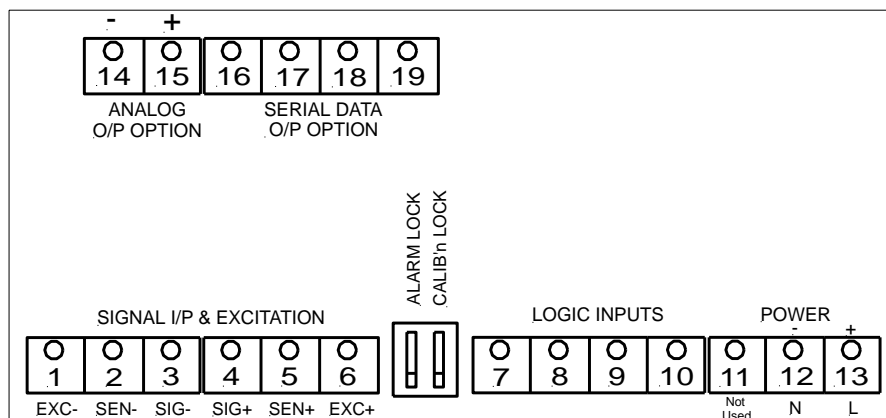

2.3 Transducer Electrical Connection Diagrams

Connections for a Cleveland Kidder Classic Semi-Conductor Transducer (one Half Bridge Transducer)

WIRING DIAGRAM
 For 1 CLASSIC Transducer

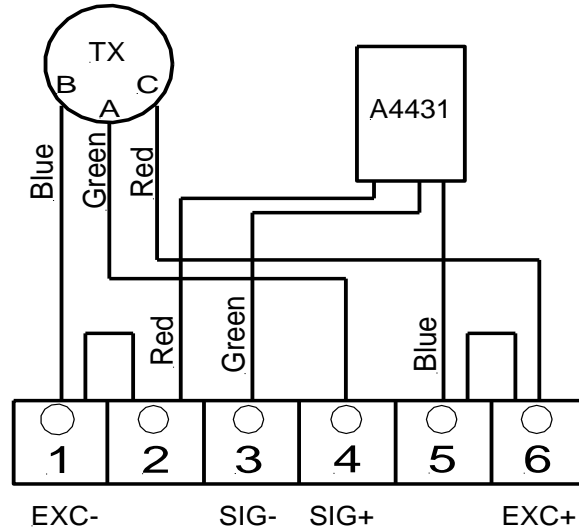

Connections for two Cleveland Kidder Classic Semi-Conductor Transducer (two Half Bridge Transducer)

WIRING DIAGRAM
 For 2 CLASSIC Transducers

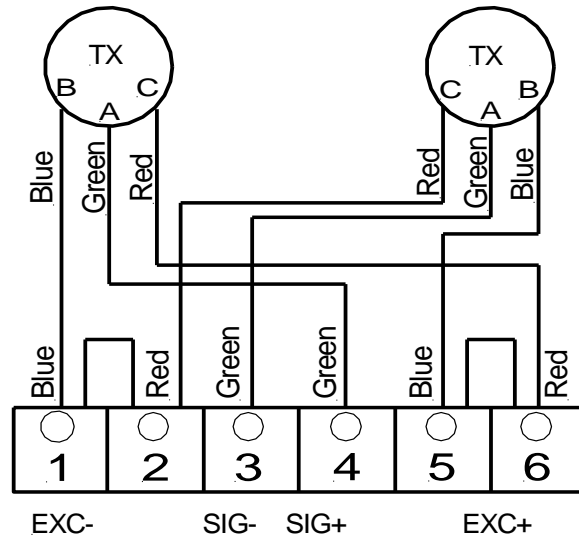

PLEASE NOTE

Connect the cable screens (green/yellow) to clean earth close to the LETIX Tension Indicator.

Connections for one Cleveland Ultra Semi-Conductor Transducer or one Full-Bridge Foil Gauge Transducer.

WIRING DIAGRAM
 For 1 ULTRA Transducer

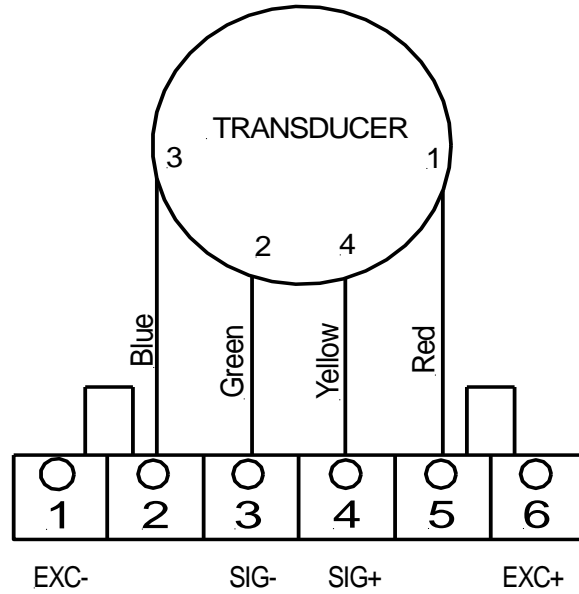

Connections for two Cleveland Kidder Ultra Semi-Conductor Transducers or two Full Bridge Foil Gauge Transducers.

WIRING DIAGRAM
 For 2 ULTRA Transducer

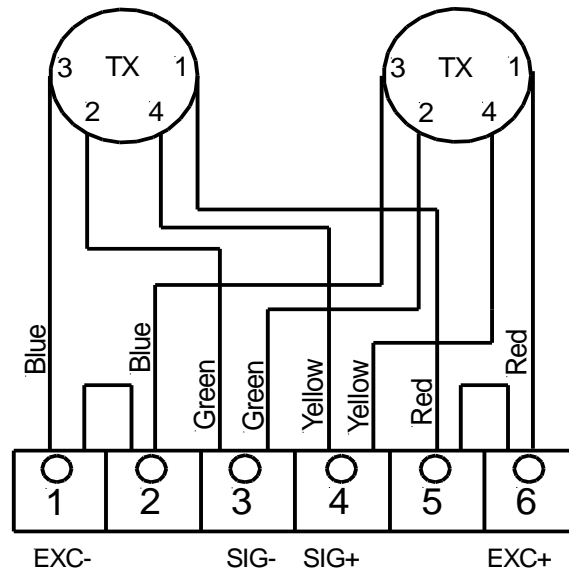

2.4 Supply Connection Diagram

WIRING DIAGRAM For Mains Power Supply

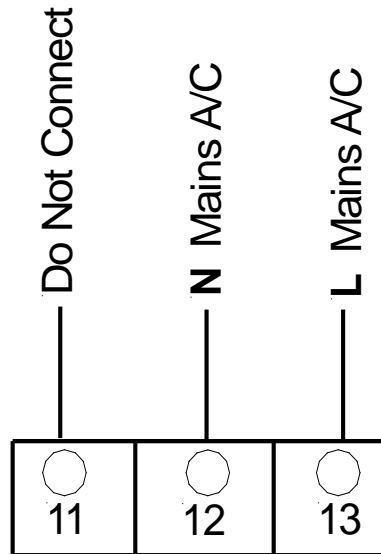

3. Supply Voltage

The LETIX is available in two power supply options, which are specified and fitted by CMC Controls before despatch according to the clients' needs.

This unit is fitted with an AC mains supply 110-230V universal. This has a RED main connector. The supply **MUST** be via a 400 mA Anti surge fuse, or similar, with a local MCB or isolator.

NOTE This unit is **not** fitted with a safety earth terminal. The protective Earth supply of the AC Mains and the screens of the transducers, and any other cable, should be bonded to earth locally with short leads.

4. Calibration

4.1 Indicator

This is usually pre-set by CMC to the clients needs before despatch, but final calibration will always need to be done on site, with the correct tension, wrap angle, roller, and transducers according to their application.

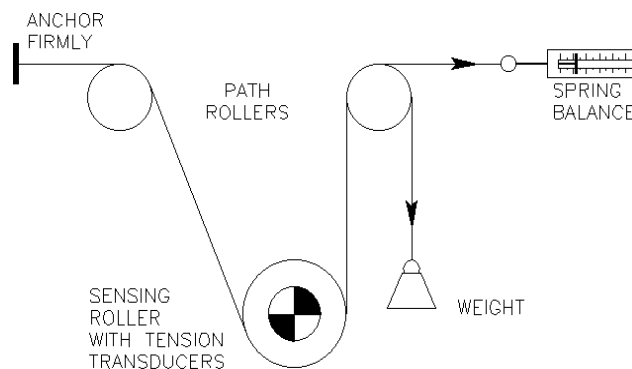

To calibrate the LETIX indicator correctly a spring balance (or weights) to provide the required tension force and some flat strapping or similar to simulate the web will be needed.

Connect the transducers correctly, and apply power to the unit. After a few seconds, it will go through the start-up routine. It is a good idea to leave the power on for 10-15 minutes to allow the transducers to settle.

IMPORTANT Before calibration, ensure that the dipswitches at the rear of the unit are set to the UP position. After calibration, set them to the **DOWN** position. This will stop the machine operator from altering the settings and prevent re-calibration of the indicator.

4.2 Direct Calibration – Full Scale Setting

With the strapping in the machine along the correct web path (as shown in the diagram), pull the maximum tension value.

Press the “**SET 2**” button for three seconds. The display will show “**direct**”, followed by “**Set Hi**”. Press “**OK**”.

4.3 Decimal Point

Press the “**SET 2**” button again for three seconds. You can now set the decimal point position with the “**UP**” or “**DOWN**” buttons. Press “**OK**” when done.

4.4 Display value

You can now set the display value you want to see. Use the “**DIGIT**” button to select each digit in turn and the “**UP**” and “**DOWN**” buttons to increase or decrease each digit’s value, as needed (for example 1500.0). Then press “**OK**” to save.

4.5 Direct Calibration – Zero Scale Setting

The next step is to remove the web tension. Then press the button marked “**SET 1**” for three seconds until the display reads “**direct**” and then reads “**Set Lo**”. Press “**OK**”. The digits will all display 00000.0, then press “**OK**” again for display to read (for example 0.0).

The input calibration is now finished, and the tension indicator should read correctly.

4.6 Output Signal Calibration

Once the tension calibration has been done, it is important that the analogue output signal (normally 0/10v = 0/100% tension) is correctly set to match the calibrated scale. Unless otherwise ordered, the indicators are shipped from CMC Controls with the output signal set to 100.0 (%) = 10.0v. Should other ranges be required, it is quite simple to alter: -

After calibrating the equipment, and the web tension has been removed, Press the “**OUTPUT**” button for three seconds. The display will show “**OUTPUT**” followed by “**0-10v**”, then “**net**”. Press “**OK**”. The display will now show “**Out Lo**” and the 0% LED will flash. Display will show 0.0 (= 0% tension). Press “**OK**” when done.

The display now shows “**Out Hi**” and the 100% LED will flash. Use the “**DIGIT**” button and “**UP**” and “**DOWN**” front panel push buttons to set the displayed value to equal the maximum tension value (for example 1500.0). Press “**OK**” when done.

The output signal from terminals 14 & 15 should now be 0/10.0v = 0/100% of the maximum tension. **Please Note** that the digital display will read numbers above the maximum calibrated value, but the output will be limited to about 10.3v above the maximum tension value.

IMPORTANT Once this has been done, set the dipswitches at the rear of the unit to the **DOWN** position. This will stop the machine operator from altering the settings and prevent re-calibration of the indicator.

5. Troubleshooting

5.1 *Digital Display Not Illuminated When Indicator Is Switched On*

- [1] Check the incoming mains supply and fuse.
- [2] (There are no internal fuses which can be replaced)

5.2 *Verify The Transducer Connections*

- [1] Measure the transducer excitation supply voltage between terminals (negative) 1 & 2 (linked) and between positive 5 & 6 (linked) and that it is correct for the type of transducer. (5v for Cleveland Kidder Classic and Ultra series, and 10v for foil type transducers). In addition, measure the differential millivolt signal at full transducer load to ensure that the unit is given signals within its correct working range.

5.3 *Check The Display Is Reading Correctly When The Transducers Are Loaded*

- [1] Check the wiring connections to the transducers, interconnecting cables, and mechanical mounting of the transducers.
- [2] Check the resistance values of the transducers, as explained in the transducer section of the handbook.
- [3] Zener Barriers (if fitted) may also need to be checked that they are correct.
- [4] Try the re-calibration procedure above.
- [5] An exchange unit is available from CMC Controls.
Contact the service department. Notify them of your problem, and a spare Indicator can be despatched against your order number and the returned Indicator repaired (or credited if found faulty under warranty).

PLEASE NOTE

This unit CANNOT be repaired in the field, and must be returned to CMC Controls.